

See discussions, stats, and author profiles for this publication at: <https://www.researchgate.net/publication/233819055>

# A Dynamic Model for Project Review in the Construction Industry

Article in *Electronic Journal of Information Technology in Construction* · March 2011

CITATION

1

READS

347

## 2 authors:



**Derar Eleyan**

Palestine Technical University- Kadoorie

56 PUBLICATIONS 520 CITATIONS

[SEE PROFILE](#)



**Peri Loucopoulos**

Institute of Digital Innovation and Research (IDIR)

287 PUBLICATIONS 4,344 CITATIONS

[SEE PROFILE](#)

Some of the authors of this publication are also working on these related projects:



Software engineering [View project](#)



Rubric [View project](#)

## A DYNAMIC MODEL FOR PROJECT REVIEW IN THE CONSTRUCTION INDUSTRY

PUBLISHED: March 2011 at <http://www.itcon.org/2011/33>

EDITOR: Turk Ž.

*Derar Eleyan,*  
*Faculty of Information Technology, Birzeit University, Palestine*  
*deleyan@birzeit.edu*

*Peri Loucopoulos,*  
*School of Business, University of Loughborough, UK*  
*p.loucopoulos@lboro.ac.uk*

**SUMMARY:** *project review plays an essential role in the project management. It evaluates the past, current situations of the project and predicts for its future. It enables project managers to understand the real situation of the project and provides them with the relevant information which enables them to make decisions as early as possible either to continue or terminate the project in order to save money and labor and invest them on another successful one. This paper introduces a new technique in conducting project review. The generic Meta model constructed in this paper captures the main important variables, which need to be considered in performing a successful project review. This Meta model introduces to construct a generic stock and flow model using system dynamics methodology. The stock and flow model enables the project management decision makers to try different situations and find out the best for the project. This model has been verified using a case study from a construction industry and simulating different scenarios.*

**KEYWORDS:** *project management, Earned Value, project review, project review Meta model, project review process model, project review stock and flow model.*

**REFERENCE:** *Derar Eleyan, Peri Loucopoulos (2011) A dynamic model for project review in the construction industry, Journal of Information Technology in Construction (ITcon), Vol. 16, pg. 577-600, <http://www.itcon.org/2011/33>*

**COPYRIGHT:** © 2011 The authors. This is an open access article distributed under the terms of the Creative Commons Attribution 3.0 unported (<http://creativecommons.org/licenses/by/3.0/>), which permits unrestricted use, distribution, and reproduction in any medium, provided the original work is properly cited.



## 1. INTRODUCTION

Project review is a process, which may take place at anytime throughout the project life. It is an evaluation and prediction process undertaken at any time during the project life cycle.(Eleyan, 2006). Evaluation aims to evaluate the current situation of a project against the main objectives of time, budget and quality through consideration of the project work as a leading parameter. Prediction aims to forecast the project's future against project time, budget and quality then compares predicted values with those forecasted. To understand the current behavior of a project, the main factors; cost, schedule, resources and quality should be reviewed. From the current behavior, it is possible to predict the future of the project, e.g., prediction of a project completion time, its budget at completion, types and amount of resources needed to undertake the future work. An early detection of variance in predicted outcomes is a concern to all Project Managers (Moselhi 2006). Project review should be an essential part of any project. To be effective, it must be in-depth and directed at full understanding of proposed solutions. The sooner the Project Manager Implements project reviews with an understanding that integrity during discussions is primary, the better chance for success to achieve.

Project review plays a major role in determining project success. A project's success can be predicted by reviewing the past performance of the participants. Project success demands timely evaluation of all activities and performance (Gaynor 1996).

A wealth of research in project management has identified variant of measures which described the outcomes of a project and the input characteristics that impact these outcomes. The most commonly cited project outcomes include cost, schedule, performance and client satisfaction. Although a general definition of project success still elusive (Farris 2006). However, traditionally project success, effectiveness and performance were related to the three principal criteria of attaining target dates, achieving financial plans and controlling the completion of a project to a specified quality (Barber and Miley 2002). The foundation of this tradition corresponds to the management concept that project success means the level of satisfaction with the achievement of the three criteria of: on time, on budget and completion of work to a specified quality. Effectiveness is related to the achievement of goals. In this way, a project's success corresponds to the effectiveness and efficiency of the project. Effectiveness is the achievement of project goals while efficiency in economic term refers to the maximization of output for a given level of input or a resource (Freeman and Beale 1992). According to Wit (Wit 1988), there is a difference between project success and project management success. Project success is measured against the objectives of a project, while project management success measured against the traditional measures of performance against time, cost, and quality.

Another distinction, which is also important to address, is the success criteria and success factors. Success criteria enable the project to be judged and measured against predefined criteria as set out of the project objectives. Success factors are those factors which, if followed, are likely leading to a successful conclusion, whilst the absence of these factors is likely leading to a failure (Cooke 2002).

This paper presents a system dynamics model to facilitate the performance of project review. This model uses a set of parameters to predict future cost and duration not only at completion but also at anytime throughout the project life. Potential cost overruns and schedule slippage are determined using the predicted results and the planned values of costs and durations. The outcome of the model simulations is useful in evaluating the project status at anytime of the project life. This model is intended to be used by members of project team when performing a project review.

## 2. SYSTEM DYNAMICS AND PROJECT MANAGEMENT

System dynamics is looking at the project as a whole - neither as a sum of parts nor as a composition of different elements or tasks, e.g. activities as reconstructing the project from its elements and calculating the duration, cost and resource requirements of the whole project from those of its elements. This concern means that system dynamics looks at the interrelationship between these different elements and the influences between each others (Sterman 1992). This approach facilitates and encourages managers to examine the feedback loops, which rule the project dynamics. The two feedback loops both balancing and reinforcing describe the major non-linear aspects in the project. System Dynamics also offers and facilitates an experimental model with management options.

Nowadays project management is treated as one of the most important fields but it is mostly a poorly understood area of management. Project management still encounters the problems of delay and cost overruns. The over schedule and over budget are considered chronic problems in different project management fields as constructions, defense, aerospace, etc. These projects often appear to be going smoothly until near the end when

errors that were made are discovered, necessitating costly rework, expediting, overtime, hiring, schedule slippage, or reductions in project scope or quality. These difficulties lead to poor profitability, loss of market share and reputation, increased turnover of management and workforce, lower productivity, higher costs, and all too frequently, divisive and costly litigation between customers and contractors over who was responsible for the overrun and delay. (Rodrigues and Williams 1998)

### 3. METHODS DEVELOPED TO PREDICT COST AND DURATION AT COMPLETION.

After any review, decisions must be made to continue, to terminate, or to continue the project with corrective actions. This decision depends on the outcome of the project review. If the decision is to terminate, this should be done quickly and as early as possible to save resources and salvage any elements that can be utilized in other projects or activities (Gaynor 1996). Therefore, forecasting project status is an essential function in tracking and control, and effectively managing projects from start to completion. Large variances in costs and /or schedules can impact profitability, cash flow, and in extreme cases, the viability of projects. As it is mentioned before, the earlier accurate prediction of these variances is the more helpful in managing projects to a successful completion. Methods developed to predict cost and duration at completion can essentially be grouped into stochastic methods, deterministic methods using earned value and its related extensions, social judgment theory, and methods based on fuzzy logic. Stochastic methods (Al Jibouri 1985) utilize the mean of the actual cost of the work performed for each cost account, referred to also as the cost at completion. These methods assume that the monthly progress of each cost account is a stationary process with a mean and standard deviation. The reliability of the forecasting model, however, is affected by the variability of the cost of unit of earning at each reporting period.

Deterministic methods using earned value (Christensen 1993; Alshaibani 1999; Zikael, Globerson et al. 2000) generally assume that either the performance efficiency achieved up to the reporting date. Some of these methods in an effort to improve forecasting accuracy, utilize cost components that make use of cost breakdown structure (Fleming and Kopelman 1999). Methods based on the social judgment theory such as that of Diekmann and Al-Tabtabai (1992) provide a way to predict the future based on a set of cues, originating from human judgment rather than from purely mathematical algorithms. These methods require experienced project managers to get satisfactory results.

#### 3.1. High-Level View of Project Review

FIG. 1 below shows simply how the project review works, ensuring that all the project objectives are met by measuring progress and taking corrective actions when necessary. This diagram depicts the project review as a process, the inputs are project plan and work performance information, its output are performance reports, forecasts, approved/rejected change requests and approved corrective actions. The project review manages the cost, scope, schedule and quality, by comparing plans with actual, it recommends corrective actions, and predicts their future effects if they are implemented. The following section will show in details the main factors and their plan and actual values by constructing a project review meta-model.

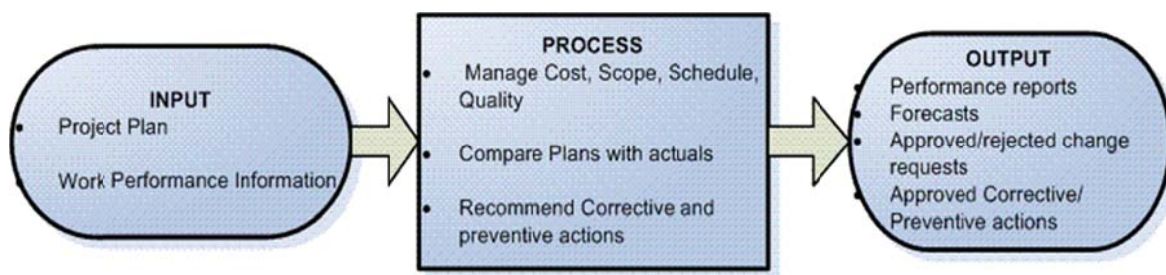

FIG. 1: Project Review Process Diagram

## 3.2. Project Review meta- Model

The Meta-model of a Project Review in FIG. 2 below confines the important variables, which construct a general project and affect its behavior. These elements are usually considered when conducting a project review.

In each milestone, Project Managers need to evaluate these elements to gain a clear picture about the actual situation of a project. This evaluation will give them a good indication about the status of a project whether the project is on track or there are some deviations or impediments. The following sections clarify each variable, discuss it in detail, and discover how can be measured and used to correctly predict the future performance of the project.

### 3.2.1. Project Work

The project work is the core of the model. It determines a project cost, schedule and resources necessary to perform the project. The project work is normally defined in detail using the Work Breakdown Structure (WBS) and shows the total work scheduled. The work scheduled is measured in working hours, which means how many working hours a project requires to perform a specified product. On each milestone, the work performed is measured and compared with the work scheduled (Kauffmann, Keating et al. 2002). The project work in FIG. 2 is a structure of different types of work attributed to different staff, e.g. the work of a project general manager, site manager and site engineer, etc., also the work of sub-contractors who are usually contracted to do a specific job as electrical, drainage, plumbing, heating and so on. Each type of resource performs its own work; the work is determined by work rate, which is the product of number of staff and their productivity. Knowing how much work is scheduled and how much has been performed, the project's current situation will be obvious and the future can be predicted depending on the project's current performance.

In FIG. 2, project work has two values: planned and actual depending on the resources (which may be planned or actual). The planned resources, the planned work to be done and the planned work rate are already determined in the project plan throughout the project planning stage. The planned staff and their planned productivity determine the planned work rate as show in equation (a):

$$\text{PlannedWorkRate} = \text{PlannedStaff} \times \text{Planned Pr oductivity} \quad [a]$$

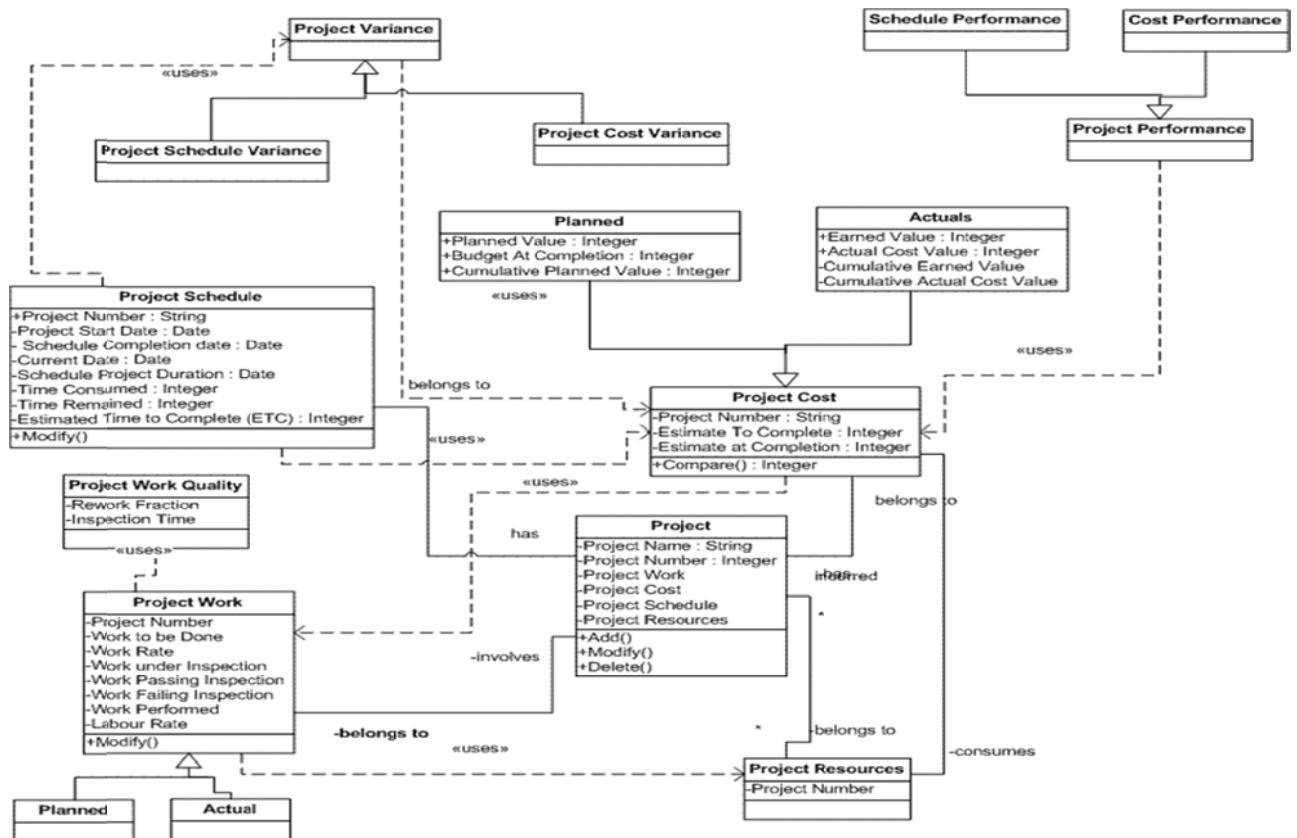

FIG. 2: Project Review Meta Model

The planned work performed is the amount of work forecasted to be performed when preparing the project plan. The planned work performed is generated from the planned work rate. The planned work done during each month is accumulated and then inspected in a project review. When the project review is conducted, the work performed is inspected against the quality standards to find defects. The work failing inspection will be added to the work to be done and will result in rework. These defects are used to determine the rework fraction. The rework fraction is the percentage of defect working hours over total working hours. After the inspection process, the work passing inspection will generate the work performed. The work performed and the planned labor rate will be used to calculate the planned value (Ahuja and Thiruvengadam 2004).

The actual work rate is calculated in the same way as planned work rate, but instead of using planned staff and productivity, the actual staff and productivity are used instead. The actual work done will also be reviewed to confront the quality standards. This process will generate defects. These defects will be added to the work to be done to get them reworked. The amount of work passing inspection will generate the actual work performed. From the actual work performed and the planned labor rate, the earned value is calculated (Anbari 2003).

There is a difference between the planned and the actual, whereas the planned is pre-prepared during the planning stage while the actual reflects the current situation. Understanding the difference between the planned and actual will lead to a better understanding of the real situation of the project.

### 3.2.2. Project Quality

Project quality is tended to be a measure of the timeliness of the deliverables and the gap between the delivered functionality and the client's requirements (Aranda, Fiddaman et al. 1993). It is normally measured by the amount of rework generated. Therefore, if the product conforms to quality standards then rework is minimum or diminished; otherwise, there is some rework to be done. Here the work performed will be inspected against the quality and other considerations to check if there are defects in the work already performed resulting in rework.

### 3.2.3. Project Cost

Project cost as shown in FIG. 3 is another important element in the conceptual model. The project cost means the amount of money needed to perform the project. In the project planning stage, the project budget is estimated and the cost is determined. When the project starts, there is a planned budget for each task to be performed; this means the planned amount of money to be spent to accomplish the project work. The planned value is determined as shown in equation (b). The planned budget is the sum of the planned values of the project which is incurred each month (Vargas 2003) as in equation (c). The cumulative planned value is the budget at completion. Each time, the planned value is calculated from the planned work performed.

$$\text{PlannedValue} = \text{PlannedWorkPerformed} \times \text{PlannedLabourRate} \quad [b]$$

$$\sum_{i=1}^n \text{PlannedValue} = \text{BudgetatCompletion} \quad [c]$$

Equation (c) shows the accumulated planned value where n is the number of time intervals in which the planned value is calculated. It is accumulated on a monthly, weekly or pre-agreed basis. It is generated as an accumulative planned value. The accumulative planned value is equal to the planned budget at the end of the project or budget at completion (Fleming and Koppelman 2000).

Equation (d) shows that the earned value is generated from the actual staff and their actual productivity but using the planned labor rate as follows:

$$\text{EarnedValue} = \text{ActualWorkPerformed} \times \text{PlannedLabourRate} \quad [d]$$

The planned labor rate is used here instead of actual labor rate because the definition of the earned value is the budgeted cost of work performed (BCWP) (Fleming and Koppelman 1999).

The third important value is the actual cost value. Equation (e) shows that the actual cost value is generated from the actual staff, their actual productivity and actual labor rate.

$$\text{Act.CostValue} = \text{Act.Staff} \times \text{Act.Productivity} \times \text{Act.LabourRate} \quad [e]$$

After generating the planned value, earned value and actual cost value of the project work already done, the project review will perform the evaluation process to evaluate the current situation of the project to generate a clear picture about the project's actual behavior, and then run the prediction process to predict its future. Earned value and planned value are used to calculate schedule variance to find if the project is performing on schedule or whether there is a schedule slippage (Energy 2004). The schedule variance is the difference between the earned value and the planned value (Barr 1996). If the difference is positive then the project is ahead of schedule, however, if it is negative then the project is behind schedule; therefore the Project Manager should take a corrective action to overcome this problem and return the project back to plan. Another important attribute, which can be an indicator of the project's schedule, is the schedule performance index, which is the division of the earned value over the planned value (Barr 1996). If the result is one then the project is on schedule, but if the result is below one then the project is facing a schedule slippage. The project review also calculates the cost variance and cost performance index using the earned value and the actual cost value to explore if the project is performing within budget or having a budget overrun. The cost variance is generated from the difference between earned value and actual cost value (Barr 1996). If the difference is positive then the project is under budget, but if the difference is negative then the project is facing budget overrun. In addition, the cost performance index is useful to explore the budget situation. The cost performance index is the division of earned value over Actual Cost value (Anbari 2003). If the result is one, then the project is within budget, but if it is less than one, then the project is going over budget.

From the cost performance index, budget at completion and earned value, it is easy to find out how much money is needed to complete the project (ETC), and how much the project will cost at the end, in other words, estimate at completion (EAC) (Vargas 2003).

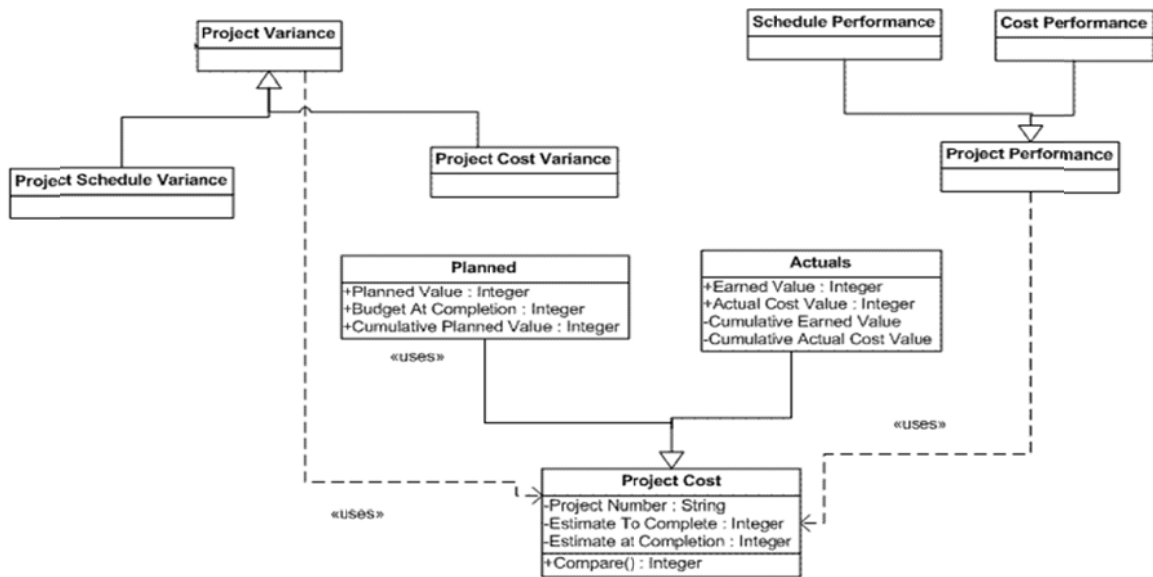

FIG. 3: Project Cost Model

Estimated to Complete (ETC) and Estimated at Completion (EAC) are related to the prediction process. The Total Project Cost is about the sum of different costs as labour cost, material cost, equipment cost and so on. The Cost Performance Index (CPI) is a proper indicator which indicates the current performance of the project and can be used to anticipate the estimated budget at completion (Anbari 2003).

### 3.2.4. Project Schedule

Project Schedule as appears in FIG. 4 encompasses variables related to schedule, as Start Date, Completion Date, Current Date, Time Consumed, Time Remained and Estimated Time to Complete (ETC), Schedule Duration and Schedule Performance Index (SPI) (Fleming and Koppelman 2000). Effective management requires the integration of the technical, schedule and cost elements of the project. Schedules resulted from this integration showing the planned time required to accomplish the technical scope of the contract and to execute the work scope, dependencies upon other work packages, and other factors. Not all work can be accomplished simultaneously. Consequently, the schedule will be adjusted by leveling the resources to conform to available budget, resource constraints and capacity of the work site among other factors.

The project schedule covers all specified work and incorporates milestones that are meaningful in terms of the technical requirements of the contract. The schedule must be derived from the plan, which contains forecasts of expected future progress. Such schedules should identify key milestones, activities and incorporate the effects of resources constraints and interrelationships between work packages. A key feature of the project schedule is that it establishes and maintains the relationship between technical achievement and progress. The project schedule should contain a master schedule and related subordinate schedules that provide a logical sequence from the detail to the summary level related to and constrained by external milestones assigned by appropriate authority. Intermediate schedules may be established if needed to provide a logical sequence from the detailed level schedules to the master project schedule. The project schedule should also provide the identification of interdependencies between organizations and WBS elements at the appropriate level for efficient project management. These interdependencies must be very visible to the Project Manager, who is the primary adjuster of the schedule, resources and scope conflicts. An effective project schedule will depict the plan to accomplish the technical scope and actual technical progress (Longworth 2002).



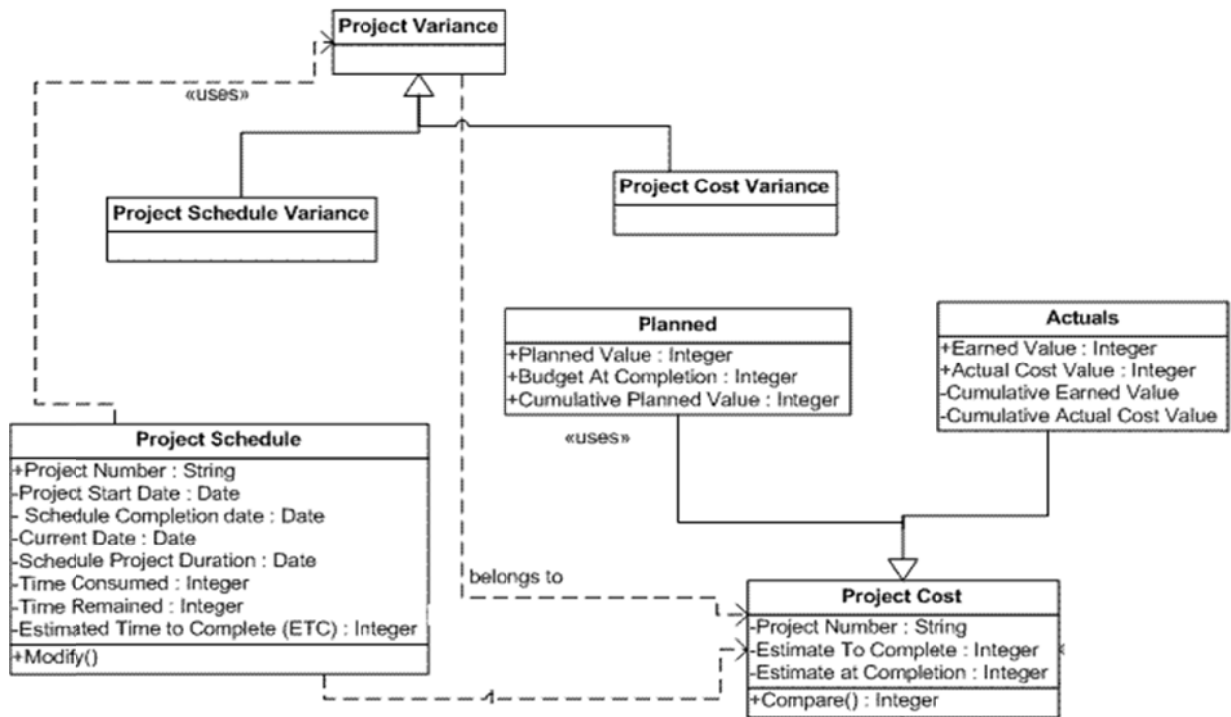

FIG. 4: Project Schedule Model

The project schedule provides information on progress against the plan, along with estimates of the time required to complete the remaining technical scope. The schedule baseline progress and estimated time to complete should be integrated with the financial view (budgets, earned value, and estimated cost to complete) of the technical scope. Scheduling should interact with other elements of the EVMS to the extent necessary for measurement and evaluation of project status (Fleming and Koppelman 2000).

In the project review, evaluating the actual situation of the project schedule will provide status and forecasts of completion dates for all authorized work. Summary and detailed schedules enable a comparison of planned and actual status of project accomplishment based on milestones or other indicators used for control purposes. When the financial data excessively lags schedule information, accurate performance measurement information will not be available quickly enough to take effective action to mitigate variances.

### 3.2.5. Project Resources

Project resources as shown in FIG 5 contain some but not all of the resources that are normally used in any project. The main, and most important resources is human resource (Hafeez, Aburawi et al. 2000); meaning the staff available to perform the project work. These resources have two values - planned and actual. The planned number of staff is already found in the project plan. Nevertheless, the actual staff is the real number of staff hired to accomplish project work. The planned staff generates the planned value and the actual staff generates the earned and actual cost value.

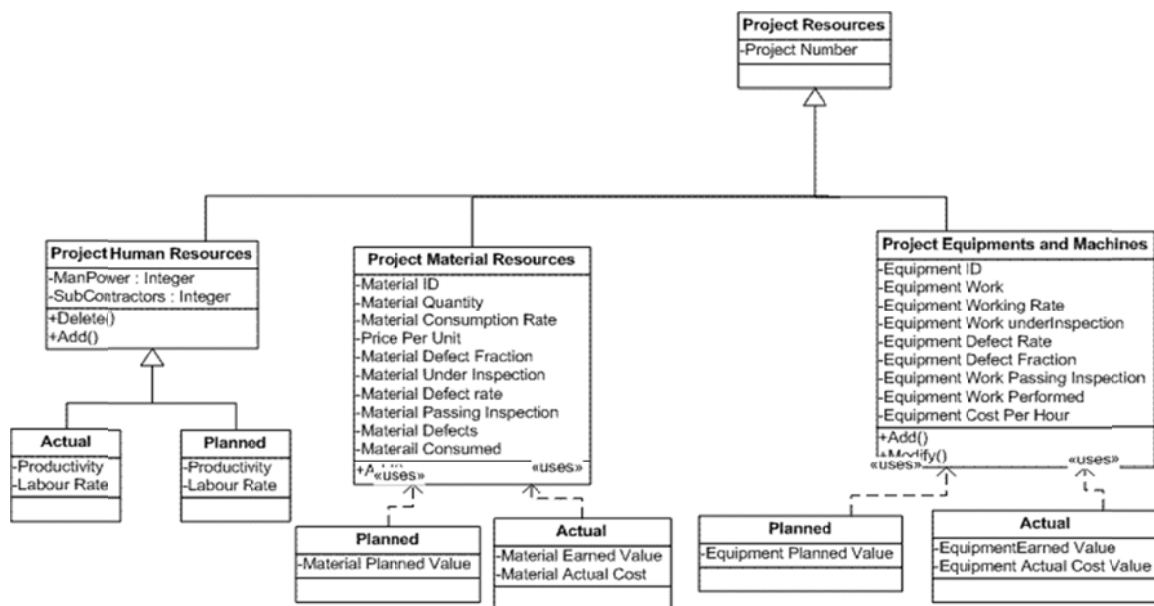

FIG 5: Project Resources Model

Other resources mentioned here but not limited to, are equipment and material resources that are essential to perform the project work.

Material resources are all materials needed for the project. Each type of material shows the quantity, the price per unit and the usage rate (Sparrow 2000). The material resources have two values - planned and actual. Material planned value is the planned amount of materials to be consumed during the project. The actual value is the actual amount already consumed to perform the project work. When conducting the project review, it is important to explore the current situation of materials, i.e. as how much material has already been used and how much more is planned. The planned to consume generates the planned value and the actual already consumed generates the earned and the actual cost values. Material planned value shows the amount of money assigned in the project plan to be spent on materials. Material earned value is the budgeted amount of money of actual material consumed. Actual material cost value is the amount of money already spent on materials already consumed.

Other resources needed to get the project work performed are equipment resources. Equipment resources show the working hours per equipment, the cost per hour for each and work rate (True 2003). Equipment resources are the same as material resources. They have three values; planned, earned and actual. Equipment planned value is the budgeted amount of money already assigned to operate the equipment. Equipment earned value is also the budgeted amount of money for the actual equipment work performed. Finally, the equipment actual cost value is the actual amount of money already incurred to perform the actual equipment work.

### 3.3. Project review Process Model

FIG. 6 below represents the project review process model. It is constituted from three main sectors. They are Project Planning Sector, Project Actual Performance Sector, and Project Actual Cost Sector. Project Planning and Project Performance represents two main stages of the project. Project Planning Sector represents the planning situation of the project and contains the project plan, while Project Actual Performance Sector represents the current situation of the project and represents the actual work performed. Project Actual Cost Sector demonstrates the real cost situation of the project. This means how much money the project has already incurred to perform the current work performed.

This model represents the generic picture of the intended model, which will be built to encompass all the details of these sectors to report project status at regular intervals. This will provide an opportunity to address potential problems early in the project when it is still possible to resolve them, which will avoid cost overruns, and schedule slippage. The project team takes a proactive approach to prevent problems from occurring. Management uses this information to resolve issues that are beyond the control of the project team. The time interval should be at least monthly, regardless of the size and duration of a project, and more frequent for some projects.

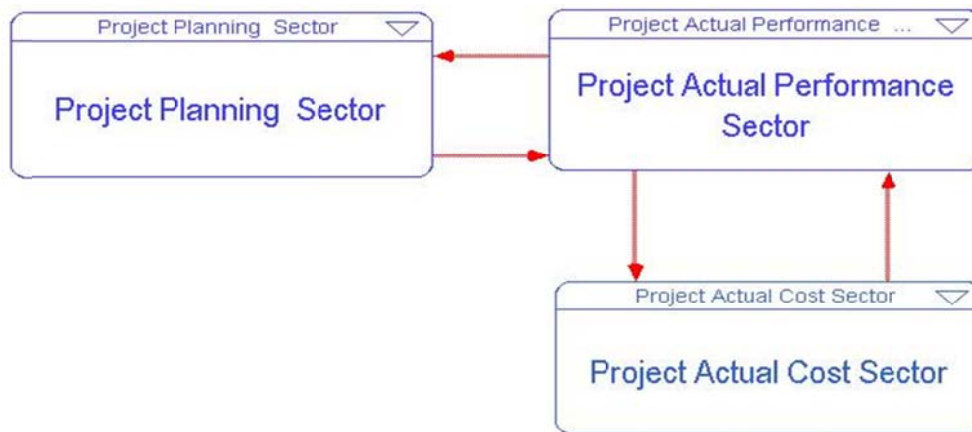

FIG. 6: Project Review Process Model

The arrows in the model indicate that there is a relation between project planning and project actual performance from one side and from project actual performance and project actual cost from the other side. The first one helps to compare plan with actual to spot the deviations in schedule, i.e. exploring schedule problems. The second one explores the cost overrun problems by comparing the actual performance with the actual cost situation.

In order to conduct a successful project review, there is a need to construct a stock and flow diagram to help project managers doing the simulation and gaining results. Stock and flow diagram is used to simulate different scenarios and to demonstrate the behavior of the major variables in the system.

### 3.4. Project Review Stock and Flow Model

The stock and flow diagrams help in simulating the model, test it with different scenarios to see how it works, and compare the results gained with the real results using a case study. This validation will judge the model and its applicability to be a project review tool. The stock and flow model is composed of three sectors. It is constructed from the previous causal loops, planning, actual performance and actual cost causal loops. Each variable in every causal loop is denoted into a new symbol - stock, flow or converter. The following sections discuss how each sector is constructed.

#### 3.4.1. Project Planning Stock and Flow Model

This model shows the main variables needed to conduct a project review. It encompasses project work, resources, and project schedule. From model simulation, it is possible to depict the plan and actual situation of the project. It is possible, therefore, to predict the project's future as it will be shown in the simulation section. After the variable types were determined, the stock and flow model was constructed and appeared in the following figure.

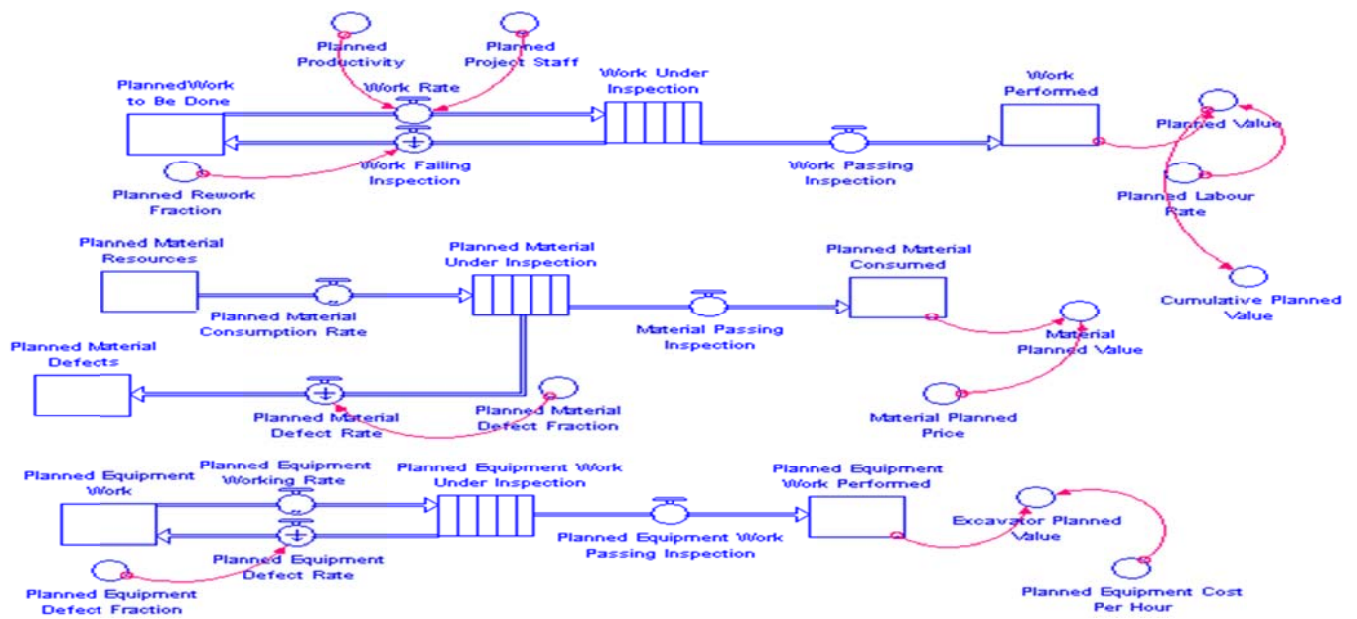

FIG. 7: Generic Project Planning Sector

Figure 7 is a reflection of the project plan. The model contains the planned work to be done, which means the working hours outstanding to complete the project. As the project progresses, the planned project work to be done will decrease in relation to the planned work rate. The planned staff and their productivity determine the work rate. These working hours are accumulated in a conveyor. After each month, a project review is conducted and work in the conveyor is inspected against quality standards. The work passing inspection will be accumulated in another stock called work-performed. The work, which fails, will be returned to the planned work to be done and reworked. The work performed is used to determine the planned value. This means that the planned value is dependent on the planned amount of work performed.

Planned-material-resources are also represented as a stock, i.e. contains all the materials needed for the project work. As the project progresses, materials used will relate to the material consumption rate. The materials consumed are accumulated in a conveyor until the end of the month when the project review is usually conducted. As the project review is conducted, the materials consumed are inspected to see how much material was actually consumed and how much was rejected. The real materials consumed will be accumulated in a stock called material consumed. From the amount of material consumed, material planned value is determined. The material defects are accumulated into a stock called planned material defects.

It is the same methodology for planned equipment work. The planned equipment work is represented as stock, which is decreased by the planned equipment-working rate. The equipment work done is accumulated in a conveyor to be inspected at the end of the month, when the project review conducted. The work passed will be accumulated in another stock called planned equipment work performed, which will determine the equipment planned value. The failed work is returned for rework. The work planned value, material planned value, and equipment planned value are then accumulated to generate accumulative planned value for the whole project.

### 3.4.2. Project Actual Performance Stock and Flow Model

Project actual performance sector is another stock and flow model. This represents the actual situation of the project. Figure 8 below shows all the variables comprising the project actual performance stock and flow model. It is assumed that the work to be done stock is the same as the planned work-to-be-done. This means that when the project launches, the work to be done is the same as planned work to be done. As the project progresses, the work to be done is decreased in relation to the actual work rate. The number of staff working in the project and their actual productivity determines the work rate. The work rate flows in a conveyor, which accumulates the work up to a month until the project review is conducted. The project review inspects the work in the conveyor to find defects. These defects are returned back to work to be done stock for rework. The work passing

inspection is accumulated in a stock called actual work performed. The actual work performed is used with the planned labor rate to determine the work earned value.

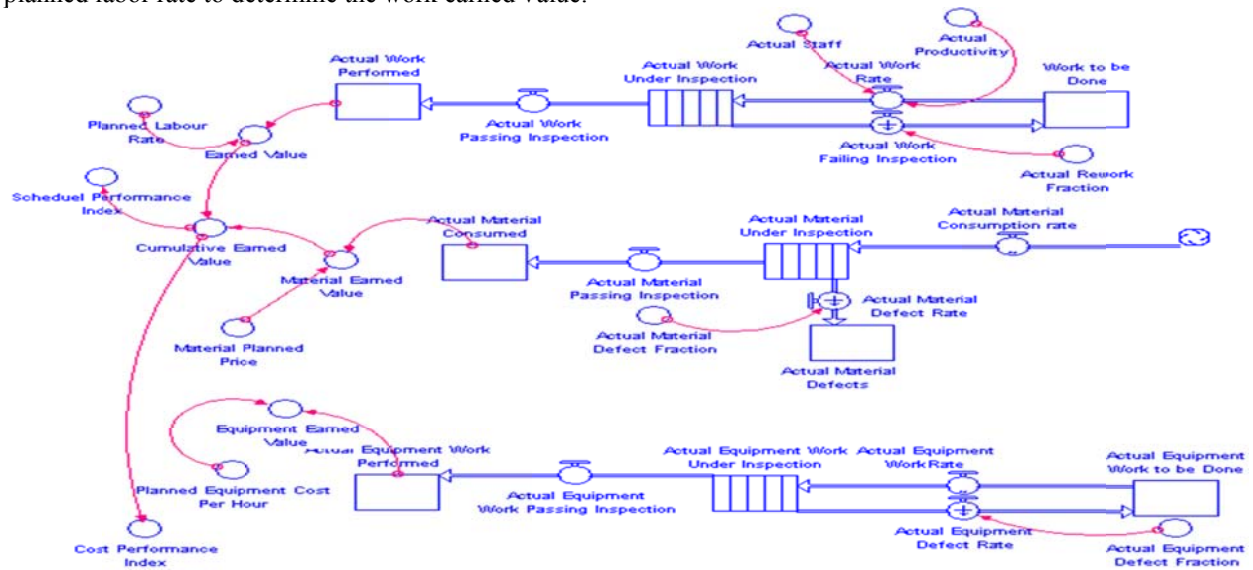

FIG. 8: Generic Project Actual Performance Sector

Besides the project work, there are material and equipment resources. These resources are required to get the project work done. The actual material consumption rate represents the amount of material consumed monthly. These materials are accumulated in a conveyor. At the end of each month, the project review is conducted. In the project review, the materials, which are accumulated in the conveyor, will be inspected. The defects are accumulated in another stock called actual material defects. The actual passing materials are accumulated in a stock called actual materials consumed. From the actual material consumed and the material planned price, the material earned value is calculated.

The actual equipment work to be done is the working hours the equipment will work to complete the project. This amount of work is represented as stock called actual equipment work to be done. This stock is decreased by the actual equipment work rate. The equipment work done is accumulated in a conveyor and inspected at the end of the month to see if it conforms to quality standards. The work passed is accumulated in a stock called actual equipment work performed. This amount of work and the planned equipment cost per hour are used to calculate the equipment earned value. The work, equipment and material earned values are accumulated to generate the cumulative earned value for the whole project.

### 3.4.3. Project Actual Cost Stock and Flow Model

The third sector of the project review model is the actual cost sector. This model is constructed in the same way as the planning and actual performance sectors. After all variables are determined, the actual cost stock and flow model is constructed as appeared in Figure 9. The accumulative actual cost is generated from work, material, and equipment cost values. The work cost value is generated from the total work done. The actual work rate is the product of actual staff and their actual productivity. This work is accumulated in a conveyor called actual monthly work. When the project review is conducted, the actual monthly work is transferred to another stock called total work. The total work and actual work labor rate are used to calculate the work cost value.

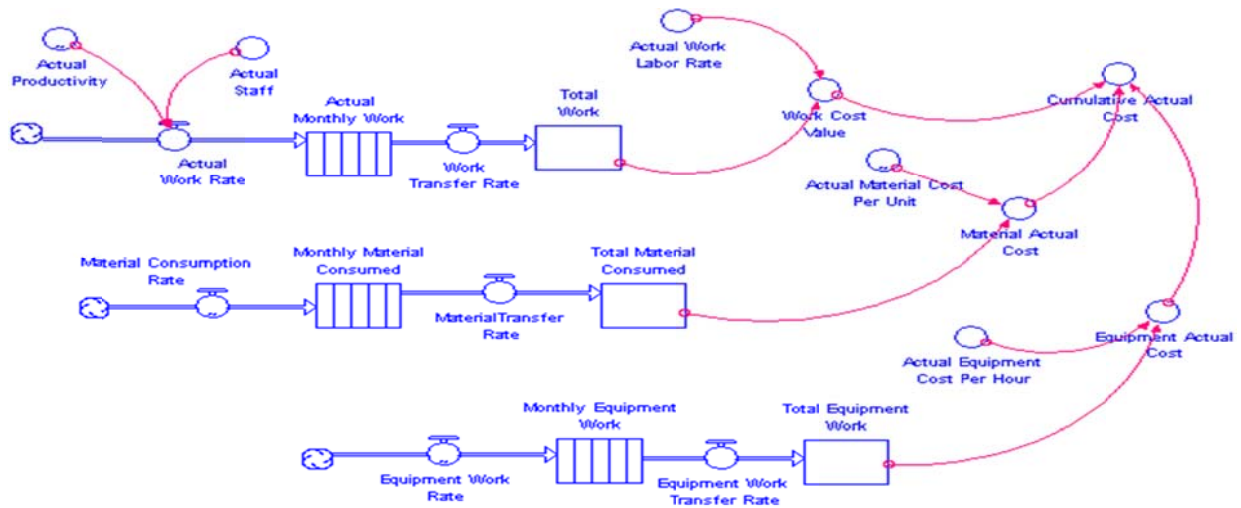

FIG. 9: Generic Project Actual Cost Sector

The material actual cost is calculated in the same way as work actual cost. All materials consumed are accumulating in a conveyor called monthly material consumed until the monthly project review is conducted. All materials in the conveyor are transferred to a stock called total material consumed. The total material consumed, and the actual material costs per unit are used to calculate the material actual cost.

The last value is the equipment actual cost. The equipment work is accumulated monthly in a conveyor called monthly equipment work. This work is transferred to a stock called total equipment work. The total equipment work and actual equipment cost per hour are used to calculate the equipment actual cost. The work cost value; material actual cost and equipment actual cost are accumulated to show the actual cost for the whole project.

### 3.5. Case Study

The case study is a construction project commenced by the ABLE Construction North West. This company operates throughout the North of England. Industrial warehouse office development is one of its successful projects. The project started on 1<sup>st</sup> October 2003 and finished on 30<sup>th</sup> September 2004, therefore, the duration of the project was a full 12 months.

The project is briefly described as follows:-

- Design, build & commission nine industrial units.
- Refurbish and remodel an existing warehouse into five starter units.
- Construct five new units built on a reinforced concrete raft foundation.
- Structural steel frame with fire protection to boundary conditions, and roller shutters to each unit.
- Each unit to contain office, toilet and kitchen with a potential to add a mezzanine floor.
- Demolition of two storey building and provision of electrical works, plumbing and heating works.
- Lay foul and surface water drainage and connect to utilities mains.
- General landscaping and stone boundary walls.
- Hot asphalt and white lining to yard and car parking areas.



### 3.6. Model Simulation

A simulation could be described as a simplified representation of a system (Drappa, Deininger et al. 1996). In the modeling process, one tries to find the behavioral rules underlying the system to be modeled. Model simulation contains work, resource and earned value simulations.

Work simulation means the simulation of different types of work planned and work already accomplished. Management work simulation for example, shows the planned management work and the actual management work. Planned and actual management works are used in calculating planned value, earned value and actual cost value. Using these values make it easy to depict the real situation of management work by calculating both the schedule and cost variances and the schedule and cost performance indexes. The schedule performance index shows the accomplishment of management work according to schedule i.e. if it is performing on, ahead of or behind schedule. The cost performance index shows the monetary situation of management work, i.e. if the work is within the planned budget, over or under budget. The model offers a simulation for all types of project work as site engineering, surveying, block work and so on (Fleming and Koppelman 1994).

Resource simulation is the simulation of both material and equipment resources. Material resource simulation aims to compare planned material to be consumed with what is actually consumed to indicate the difference between planned and actual. This helps to find the accuracy of the planning process by depicting the difference between planned, earned and actual.

Equipment simulation aims to compare the planned equipment needed to perform project work and actual equipments used. This gives a clear picture, shows the difference between planned, earned and actual, and shows the accuracy of the planning process.

#### 3.6.1. Work Simulation

The model offers the ability to simulate planned project work and actual project work. Simulation of planned project work is helpful in the planning phase to assess accuracy and to discover whether the work is on course to be finished as per the planned schedule using the available resources, or whether it will exceed it and need more resources. For example, in the project-planning phase, the project team determines the amount of work needed to perform management tasks in the project. The model is useful in verifying the accuracy of planning by feeding it with the amount of work planned and assess when it will finish. The following figure show an example of the planned management work simulation.

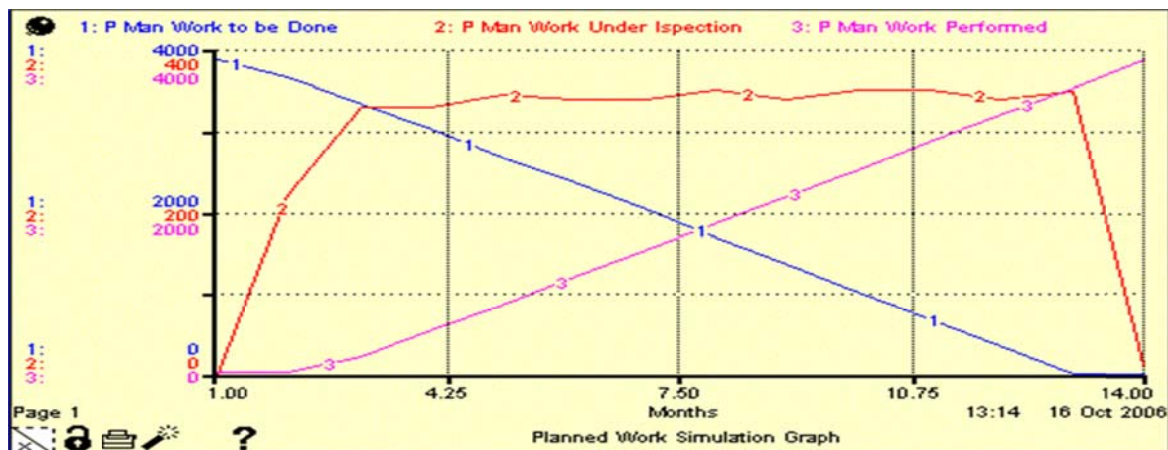

FIG. 10: Graph shows planned management work simulation

It is clear from Figure 10 that planned management work to be done is going to be completed by the end of month 12 as planned. A few hours represent the defects, which resulted from the project review process. Here the defects are about 10 hours; therefore, the Project Manager could consider performing this rework during month 12 or the forthcoming months by increasing the work to be done in that month.

Simulation of actual project work helps to ascertain the true progress of the project. This enables the user to compare what was planned against what has actually been completed, to see if the project is performing as planned, behind or ahead of plan. This gives the Project Manager the opportunity to implement corrective action to adjust the project during the early stages before problems occurs. The following figure shows an example of a simulation of actual project management work.

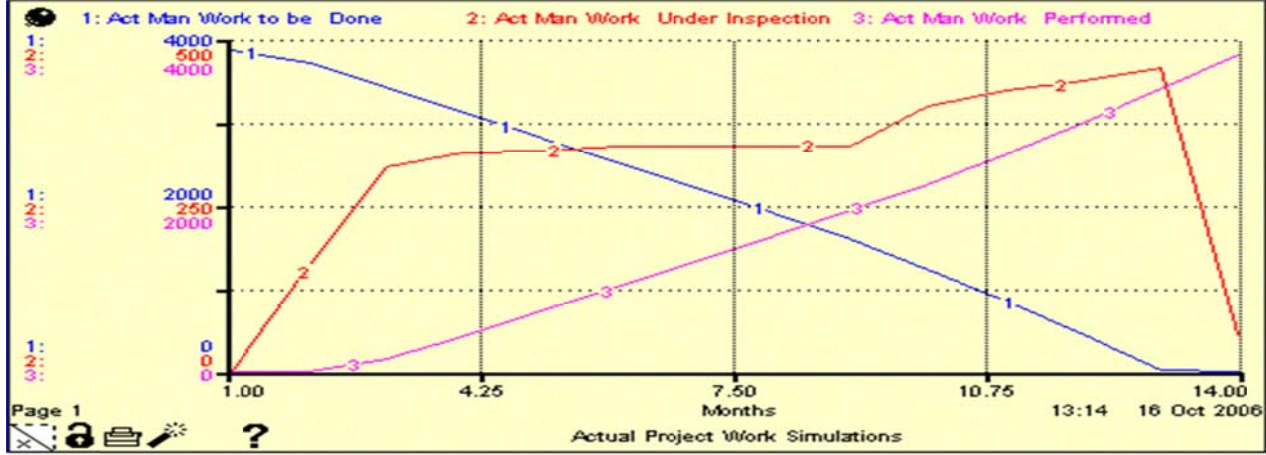

FIG. 11: Graph shows actual management work simulation

Figure 11 shows that the project’s actual work was finished at month 12 as planned. Using Figure 10 and Figure 11 to compare the planned work and actual work will enable the Project Manager to understand the situation of the project work and ascertain if the work can be completed as planned or whether it requires corrective action to bring it back on schedule.

The other type of simulation the model offers is the Project Resources Simulation. The two main resources in this model are material and equipment resources. The other resource is human resources, which was used in the project work simulation

**3.6.2. Material Resources Simulation**

Material resources simulation is used to show the materials planned value, material earned value and material actual cost. In addition to these values, the model facilitates the calculation of material usage variance, which is the difference between the budgeted use of materials and their actual usage. Material planned value refers to the budgeted amount of money planned to purchase materials needed to carry out project work. Material earned value is the budgeted amount of money for the actual amount of materials already consumed in the project. Material actual cost is the amount of money incurred from using the actual amount of materials in the project. Figure 12 below shows materials planned, earned and actual cost values.



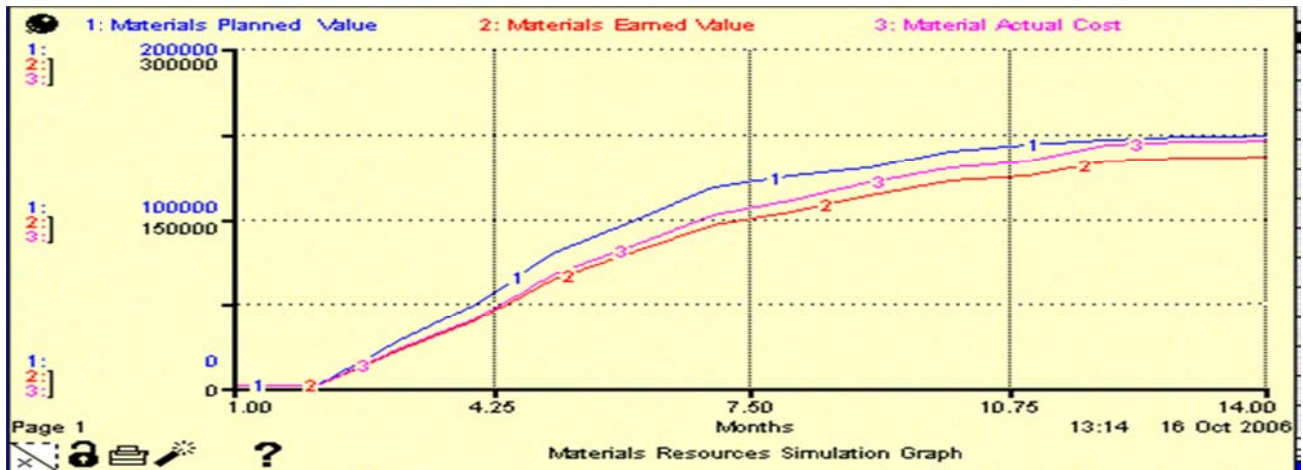

FIG. 12: Material Planned Value Earned Value and Actual Cost Value

Material simulation helps in understanding the material usage and enables the Project Manager to take corrective action to reduce the actual cost through either reducing the usage rate or sourcing more cost effective material alternatives to do the same work. The material usage variance refers to the difference between the planned material to be consumed and the actual materials as shown in equation (f).

$$\text{Material Usage Variance} = \text{Material Planned Value} - \text{Material Actual Cost Value} \quad [f]$$

This will be used as an indicator. If the variance is zero then what was planned is consumed, meaning that the amount of material planned is what the project required with no need to purchase more material. However, the table below shows that at the end of the project the difference was £70,421.37 meaning that materials consumed was much more than material planned. To reduce the difference, it is possible to substitute more cost effective alternative materials.

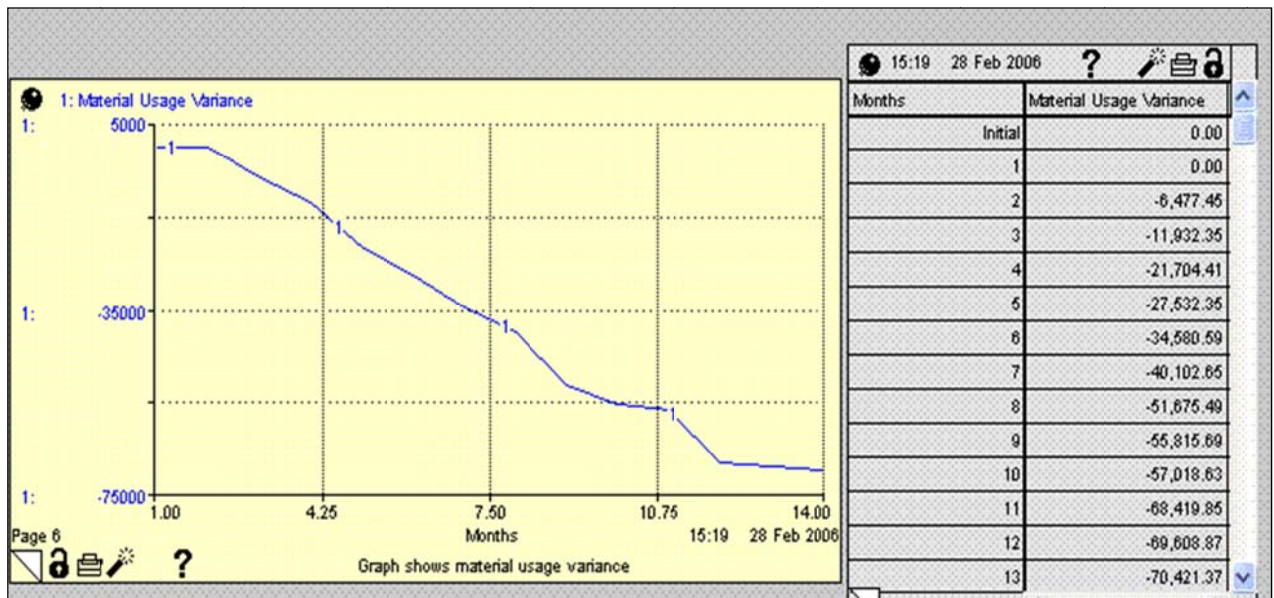

FIG. 13: Material usage variance

Another important comparison is to find out how accurate the materials were planned when the materials earned value is compared with the materials planned value as shown in the following table.

TABLE 1: Comparison between material planned value and material earned value

Months	Materials Planned Value	Materials Earned Value
1	0.02	0.02
2	26,372.57	31,893.22
3	49,117.66	59,271.86
4	78,970.61	95,631.08
5	99,117.66	120,291.28
6	118,529.43	143,932.06
7	124,882.37	155,000.02
8	130,274.53	170,436.91
9	139,784.33	182,961.18
10	143,431.39	187,669.92
11	146,617.66	201,174.77
12	148,068.64	203,504.87
13	148,068.64	204,262.15

Table 1 shows there was a difference between material planned value and material earned value. When the earned value is more than the planned value, this is against the principles of the earned value. The principles stated that the final earned value should not exceed the final planned one. This is from the definition of the earned value, which states that the earned value is the budgeted amount of money for the actual work performed or material consumed. Therefore, the gap between the material planned value and the material earned value shows that the planning process of material resources was not accurate and required revision.

**3.6.3. Equipment Resources Simulation**

Equipment Resources Simulation is the same as material resources simulation. It shows equipment-planned value, equipment earned value and equipment actual cost value. Equipment planned value explains the budgeted amount of money assigned to buy or hire equipment that was needed to perform the project work. Equipment earned value is the budgeted amount of money for equipment already used in the project. Equipment actual cost value is the actual amount of money already incurred to buy or hire equipment.



FIG. 14: Equipment Planned Earned and Actual Cost Values

Figure 14 above shows the monthly equipment planned, earned and actual cost values. The Project Manager compares these values to get clear view of the equipment resource situation. The equipment planned and earned values are approximately close to each other but the equipment actual cost shows that it is more than the planned and earned meaning that the project hired more than it planned or the actual cost per hour exceeded the planned cost per hour and incurred more cost.

#### **3.6.4. Earned Value Simulations**

Earned Value Simulations consider cumulative planned, earned and actual cost values and uses them to calculate some important indicators to help understanding the overall situation of the project. The correlation among these values allows for the verification of results for the project and continues the evaluations and future projections of final cost and duration. In order to relate between these three values there are the following indices and variances.

#### **3.6.5. Cost Performance Index and Cost Variance**

Cost Performance Index (CPI) is the ratio between the Earned Value (EV) and the Actual Cost (AC) (Vargas 2003). The CPI in equation (g) indicates the conversion between AC used by the project and the EV in the same period, and provide information to show how much is earned of what was already spent.

$$CPI = EV / AC \quad [g]$$

When CPI equals one, the value spent by the project is integrally earned to the project and it is within budget. When the CPI is less than one, the project is spending more than planned when the calculation was made. If the CPI is more than one, the project costs are less than forecasted when the calculation was made.

Cost variance (CV) is the comparison between the values of the work performed with the actual cost of work performed. CV in equation (h) is an objective indicator. It is the money value of what is accomplished for the resources expended. Mathematically it is expressed as-

$$CV = EV - AC \quad [h]$$

A positive cost variance indicates that the work is accomplished for less resource expenditure than earned. A negative cost variance indicates that the work accomplished costs more than earned resource value (Vargas 2003). From the equation above, CV is determined by the EV and AC. If the project is over budget according to the value of CV, it would be possible to bring the project back to the budget line by manipulating the actual cost value to reduce the actual cost which will reduce the CV. This will happen by seeking alternatives to the resources used in order to lessen the costs incurred e.g., for human resources it may be possible to hire less skilled staff (Barr 1996).



TABLE 2: Cost Variance and Cost Performance Index

Months	Cumulative CPI	Cumulative Cost Varia
Initial	0.00	-260.99
1	0.00	-260.99
2	0.94	-6,400.28
3	0.94	-14,019.31
4	0.93	-26,574.35
5	0.93	-35,195.03
6	0.93	-47,031.66
7	0.93	-56,392.40
8	0.93	-68,615.05
9	0.93	-79,099.09
10	0.93	-91,063.65
11	0.92	-106,939.63
12	0.92	-117,460.82
13	0.91	-141,126.36

Table 2 shows the values of both the cost variance and cost performance index. It shows that at the beginning of the project, the cost performance and cost variance were low. This is expected as the earned value would be low as the work performed would be minimal. As the project progresses, the performance improves gradually, reaching 94% at months 2 and 3 and decreasing to 93% from months 4-10, and reducing to 92% at the end of the project. This simulation demonstrated that the CPI did not significantly improve during the period between the 15% and the 85% of contract performance. In fact, it declines towards the end of the project. This can be used as an early warning that the project is going to be over budget as the CPI was less than one. This would be an opportunity for the Project Manager to implement corrective action to remedy the variance.

### 3.6.6. Schedule Performance Index and Schedule Variance

Schedule Performance Index (SPI) as in equation (i) is the ratio of the Earned Value (EV) over the Planned Value (PV) (Energy 2004). The SPI shows the conversion rate of PV and in EV.

$$SPI = EV / PV \quad [i]$$

When SPI equals one, the planned value is performing to schedule. When SPI is less than one the project is performing at a lower conversion rate than forecasted and the forecasted financial amount to be earned in the period defined could not be obtained. When SPI is higher than one, then the project is earning results faster than expected and it is ahead of plan.

Schedule Variance (SV) is another schedule indicator (Vargas 2004); and is obtained from the comparison between the values of work performed with the values of work scheduled. SV is a subjective indicator and does not reveal the critical path (Vargas 2004). SV in equation (j) is an aggregate money value of events ahead or behind schedule. Mathematically, it is expressed as follows:

$$SV = EV - PV \quad [j]$$

A positive schedule variance is an indication that in-process work is ahead of schedule. A negative schedule variance indicates that in-process work is behind schedule. From the equation above SV is determined by EV and PV, if the project is behind schedule according to the value of SV it is possible to return the project to plan by manipulating the earned value, thereby increasing the earned value, which causes a reduction in the SV. This would happen by adopting an overtime program either by increasing the productivity of the staff or increasing the number of staff hired.

TABLE 3: Schedule Variance and Schedule Performance Index

Months	Cumulative Schedule Variance	Cumulative SPI
Initial	-12.02	0.00
1	-12.02	0.00
2	-4,036.43	0.96
3	-16,756.78	0.93
4	-32,797.82	0.92
5	-50,178.36	0.91
6	-61,624.34	0.91
7	-69,486.25	0.92
8	-68,516.77	0.93
9	-65,855.91	0.94
10	-40,571.34	0.97
11	4,621.45	1.00
12	32,557.39	1.02
13	51,098.35	1.03

Table 3 shows a graph and table of schedule variance and performance. From the graph, it is clear that the project performance began at zero before work began and it improved to 96% at the end of the first month. Performance reduced to 91% in months 5, 6, and improved to 97% in month 9. After month 9 the Project Manager decided to increase productivity in order to complete the project on time and in month 10 the rate increased to one and above. The schedule performance and schedule variance were useful as they indicated that the schedule was slipping behind plan, giving the Project Manager the opportunity to implement corrective action.

### 3.6.7. Percentage Complete and Spent

One of the advantages of an EV reporting system is the ability to determine precisely and objectively the percent complete of a project in a budget sense and in work complete as shown in equation (k) and (l). The definition is-

$$\text{Percent Complete} = \frac{\text{WorkComplete}}{\text{Totalwork}} \quad [k]$$

$$\text{Percent Complete} = \frac{\text{EarnedValue}}{\text{BAC}} \times 100 \quad [l]$$

$$\text{BAC} = \text{Project Measurement Baseline} + \text{Management Reserve} \quad [m]$$

Project Management Baseline (PMB) is the two values of the project planned value which is equal to £1,472,761 and the Management Reserve which is equal to £62,195; therefore the BAC equals £1,534,956. In order to portray accurately the project percent complete, the BAC as in equation (m) should include any contingency, management reserve, and summary level budgets. Most organizations like to correlate the percent complete with the percent spent of a project in a funding sense as shown in equations (n) and (o). The definition is:

$$\text{Percent Spent} = \frac{\text{MoneySpentToDate}}{\text{TotalExpectedExpenditures}} \quad [n]$$

$$\text{Percent Spent} = \frac{\text{AC}}{\text{EAC}} \quad [o]$$

The denominator reflects the best projection of final cost. The comparison between percentage complete and percentage spent reveals how fast money is being spent compared with how fast the work is being completed. From Table 4 below, it is clear that the project was progressing at the same percentage rate of spending related to EAC, so the EAC is also realistic.

Table 4: Percent completed and percent spent

Months	Percent Complete	Percent spent
Initial	0.00	0.00
1	0.00	0.00
2	6.25	6.25
3	14.12	14.12
4	23.98	23.98
5	32.01	32.01
6	40.72	40.72
7	48.85	48.85
8	57.47	57.47
9	65.89	65.89
10	74.70	74.70
11	84.33	84.33
12	92.13	92.13
13	98.82	98.82

### 3.6.8. Estimated Completion Date (ECD)

ECD means the date that the project is forecasted to finish. There are several methods available to calculate the number of months required to complete the work remaining. The ECD is determined by dividing project duration over SPI. The ECD as in equation (p) is calculated using the following equation:-

$$ECD = \frac{\text{Project Duration}}{SPI_{Cum}} \quad [p]$$

Where project duration=12 months, which is the planned time needed to complete the project and  $SPI_{Cum}$  is the cumulative schedule performance index. Figure 18 shows the estimated completion date.

TABLE 5: Estimated Completion Date

Months	Estimated Completion date
Initial	5,391.90
1	5,391.90
2	12.50
3	12.93
4	13.07
5	13.23
6	13.18
7	13.11
8	12.93
9	12.78
10	12.42
11	11.96
12	11.72
13	11.60

Table 5 shows that the project started with a large ECD as the SPI was nearly zero. As the project progressed, the ECD became more realistic, showing an approximation date for the project to be completed. The ECD on month 10 and after shows a near value as the project was accelerated to overcome the schedule slippage, which appears here in the estimate at completion-simulated values.

#### 4. CONCLUSION AND FUTURE RESEARCH

The aim of the paper is to develop a generic system dynamics model to assist a Project Manager to carry out an effective project review. This model is used to track and control the project in terms of schedule, budget and quality. To achieve this aim the first step was conceptualizing a generic conceptual model. The model includes the essential factors to conduct a successful project review. These factors are project work, resources, cost, schedule and quality. This model captured the essential variables for each factor. These variables in the conceptual model are classified into three sectors according to their tasks. The variables attributed to planning are confined into the planning sector. The variables attributed to the project actual performance are confined into the project actual performance sector and the variables attributed to the project actual cost are confined into the actual cost sector. The variables in each sector are connected together according to the relation between them showing the cause and effect by constructing a causal loop for each sector. These sectors are important to gain a whole picture about the current state of the project in terms of schedule, budget and quality. Constructing a stock and flow model is essential to run the simulation process in order to depict the actual picture of the whole project. This model is constructed from three sectors; planning, actual performance and actual cost sectors. Each sector fulfils a job in the project review. For example, the planning sector reflects the project plan, which means how the project work is planned. The actual performance reflects the situation of the project and shows the actual staff working on it and their productivity and how much work is passed and how much is rejected when the inspection is carried out in the project review. The actual cost sector reflects the actual cost and expenditure situation. It shows the actual cost spent so far to perform the project work. Depicting these three situations will help the Project Manager to understand the current situation of the project and enables him/her to accurately predict the project future performance.

The model is evaluated using a case study from a construction industry. It has been selected from a construction industry because the construction projects are well defined and the project baseline plan consists of: 1) a detailed schedule containing all the authorized work, 2) schedules containing the authorized resources to conduct the work, and 3) payments by the cost manager to contractors based on their physical accomplished work, together with the original authorized budget for the work.

The model can be used as an approach to scrutinize the plan. The model provides a good facility to test the planning values in order to see if they are effectively planned. For example, the model can be fed with the values of the number of staff planned to conduct the project work, their productivity and the amount of work needed to be done, in order to foresee if the staff and the productivity are adequate to perform the required amount of work. The previous implementation of the model shows how it is beneficial. The model is used to verify the project plan, actual performance and cost when the model compares the earned value and the actual cost for each type of work and resources. In addition, it examines the earned value to calculate if it is greater than the plan –the planning values must be revised in order to ensure that the planning process was accurate

From the implementation of the system dynamics model on the case study, it is quite apparent that the model encompasses the essential factors needed to conduct a successful project review as shown in the meta-model. The model considered different types of human factor according to the type of work they performed, and considered different types of material and equipment resources and how to measure their consumptions and defects.

However, the model shows that there is a need for expansion and future works requiring more effort and further research are the following:



#### 4.1. Level of Experience and Staff Required

To enhance the project review system dynamics model, human resources should be extended and included their level of experience. Including the level of experience will facilitate how to determine and measure the review fraction for the future. If the level of experience is increased then the review fraction would decrease and rework needed would decrease. This is important when thinking about the level of experience required to reduce project costs or rescue the project from budget overrun. The review fraction also affects the project's duration. Further research is also needed to compromise between the level of experience on one side against cost and duration on the other.

Also, during the project review, there is a need to know the staff required to finish the project work to plan and their level of experience against the type of work outstanding. When the project review is conducted, two processes take place, one is the evaluation and the other is prediction as discussed in the state of the art. In order to get the project completed on schedule, it is important to know how many staff needed depending on the evaluation process. The required staff is estimated based upon the volume of work to be done, the time horizon to completion, productivity, and quality.

#### 4.2. The impact of adding more resources

Using the model to measure the influence of adding more resources during the project life to complete the project on schedule, more attention should be paid to Brooks' law, which says that adding more resource to a late project will cause it to be later. It is important, therefore, to enhance the model to a level which shows the threshold where adding more resources will cause more delays and how this impacts the project finish date and budget at completion. Moreover, the model should determine the level of experience of the staff required and the length of time needed to make them produce quality work, including the training needs to assimilate them in the project.

#### 4.3. Overtime duration

What are the factors that affect the duration of overtime or increasing the staff productivity? The overtime policy is one of the prominent alternatives the project manager thinks of when the project is suffering from schedule slippage. Increasing productivity will help to recover the schedule overrun. This needs further research. For example, when overtime adopted to increase the productivity may have a negative impact on project duration and causes a reduction in staff productivity due to staff fatigue. It is imperative to cease this practice before this occurs.

### 5. REFERENCES

- Ahuja, V. and V. Thiruvengadam (2004). "Project Scheduling and monitoring: Current research status." Construction Innovation Vol. 4: pp. 19-31.
- Al Jibouri, S. H. (1985). Cost models for construction, PhD Thesis. Nottingham, UK, University of Nottingham.
- Alshaibani, A. (1999). A computerized cost and schedule control system for construction projects, Master Thesis. Montreal Canada, Concordia University.
- Anbari, F. T. (2003). "Earned Value Project Management and Extensions." Project Management Journal Vol. 34(4): pp. 12-23.
- Aranda, R. R., T. Fiddaman, et al. (1993). "Quality micoworlds: modeling the impact of quality initiatives over the software product life cycle,." American Programmer Volume 6(No. 5): pp. 52-61.
- Barber, E. and F. Miley (2002). Monitoring project progress: More than a series of feedback loops. Australian Evaluation Society International Conference, Wollongong Australia.
- Barr, Z. (1996). "Earned Value Analysis: Case Study." PM Network, X(No. 12): PP. 31-37.
- Christensen, D. S. (1993). "Determining an accurate Estimate At Completion." National Contract Management Association Journal Vol. 25: pp. 17- 25.
- Cooke, D. T. (2002). "The "real" success factors on projects." International Journal of Project Management Vol. 20: pp 185-190.



- Drappa, A., M. Deininger, et al. (1996). Modeling and Simulation of Software Projects, Software Engineering Group, University of Stuttgart, Brietwiesenstr, Stuttgart, Germany.
- Energy, U. S. D. o. (2004). Earned Value Management, Application Guide, United States Department of Energy.
- Farris, J. A., Groesbeck, R. L. (2006). "Evaluating the Relative Performance of Engineering Design Projects: A case Study Using Data Envelopment Analysis." IEEE Transactions on Engineering Management **Vol. 53**(no. 3): pp. 471-482.
- Fleming, Q. and J. Koppelman (1994). "The essence and Evolution of Earned Value." Transactions of AACE international: pg. 73.
- Fleming, Q. W. and J. M. Koppelman (1999). Earned Value Management. Newton Square, Project Management Institute.
- Fleming, Q. W. and J. M. Koppelman (2000). Earned Value Project Management (2nd Ed.). Newtown Square, Project Management Institute.
- Freeman, M. and P. Beale (1992). "Measuring Project Success." Project Management Journal **Vol. 13**(No. 1): pp. 9-16.
- Gaynor, G. (1996). "Monitoring Projects- It's More than Reading Reports." Research Technology Management **Vol. 39**(No. 2): pg. 45.
- Hafeez, K., I. Aburawi, et al. (2000). Human Resource Modeling Using System Dynamics. Sheffield, School of Computing and Management Sciences, Sheffield Hallam University.
- Kauffmann, p., C. Keating, et al. (2002). "Using Earned Value Methods to Substantiate Change-Of-Scope Claims." Engineering Management Journal **Vol. 14**(No. 1): pg. 13.
- Longworth, S. (2002). "Evolving Project Control Practices." AACE International Transactions: pg. CS41.
- Moselhi, J. (2006). "Forecasting Project Status by Using Fuzzy Logic." Journal of Construction Engineering and Management **Vol 132**(No. 11): pp 1193-1200.
- Rodrigues, A. G. and T. M. Williams (1998). "System dynamics in project management: assessing the impacts of client behaviour on project performance." Journal of the Operational Research Society **Vol. 49**: pp 2-15.
- Sparrow, H. (2000). EVM...Earned Value Management Results in Early Visibility and Management opportunities. 31st Annual Project Management Institute Seminars and Symposium, Houston.
- Sterman, J. D. (1992). System Dynamics Modeling for Project Management. Cambridge MA, Sloan School of Management, Massachusetts Institute of Technology.
- True, L. (2003). "Do You Really Know Your Construction Costs?" Journal of construction Accounting & Taxation **Volume 13**(issue 3): pp. 5-10.
- Vargas, R. (2003). "Earned Value Analysis in the Control of Projects: Success or Failure." AACE International Transactions: pg. CS 211.
- Vargas, R. (2004). "Earned Value Probabilistic Forecasting Using MonteCarlo Simulation." AACE International Transactions: pg. CS 161.
- Wit, A. (1988). "Measurement of project success." Project Management Journal **Vol. 6**: pp. 164-170.
- Zikael, O., S. Globerson, et al. (2000). "Evaluating of models for forecasting the final cost of a project." Project Management Journal **Volume 31**,(No.1): PP. 53-57.